



# HGS (INDIA) LIMITED



## HGS 5055 Connector Assembly



158, Sector-4, IMT Manesar, Gurugram-122050, Haryana, INDIA  
Tel: +91 (0124) 4681800  
Email: sales@hgsindia.com



# HGS (INDIA) LIMITED



## SCHEMATIC

### HGS 5055 Connector Assembly

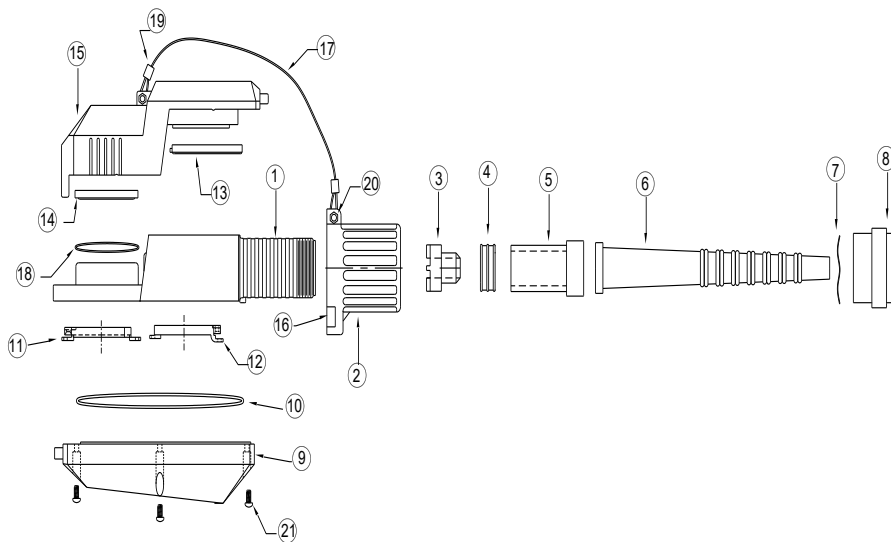

SR.NO.	QTY.	DESCRIPTION
1	1	CONNECTOR BODY SUB ASSY.
2	1	CAM HANDLE
3	1	CABLE ANCHOR
4	1	GROMMET
5	1	SPACER
6	1	CABLE BOOT
7	1	WAVE SPRING
8	1	GLAND NUT
9	1	BACK COVER
10	1	COVER GASKET
11	1	SOCKET RETAINER ASSY.
12	1	PIN RETAINER ASSY.
13	1	PIN GASKET
14	1	SOCKET GASKET
15	1	ASSY. COVER(WATER TIGHT COVER)
16	1	CAM HANDLE INSERT
17	1	INSULATED WIRE ROPE
18	1	O'RING
19	2	FERRULE
20	2	SCREW & NUT
21	6	PHILIPS PAN HEAD SCREW

158, Sector-4, IMT Manesar, Gurugram-122050, Haryana, INDIA

Tel: +91 (0124) 4681800

Email: sales@hgsindia.com



# HGS (INDIA) LIMITED



## SPECIFICATIONS

### HGS 5055 Connector Assembly

- Connector Capacity: up to 256 contacts.
- Cable Capacity: upto 2.03 cm.
- Contact Size: 14 AWG, Solderable, Gold Plated.
- Water Proof.
- Impact modified polyester.
- Rigid mounting prevents rotation of individual pins & socket.
- Coupling: Cam action with positive lock.
- Cable anchor to prevent lateral & rotational movement of cable.
- Maximum strength in rugged field condition.
- Fitted with water tight assembly cover.
- Operating Temperature Range: -20°C to +70°C
- Pressure Rating: Up to 3 bar

Version 1.2